



Intelligent Automatic Flat Door system

Catalog

1	Technical parameter	1
2	Description of accessories	2
3	Mechanical installation	3-9
3.1	Installation example	3
3.2	Baseboard installation	4-5
3.3	Arm installation	6
3.4	Push arm installation	7-8
3.5	Driver system installation	9
3.6	Hood installation	9
3.7	Connection of drive system and pull arm	10
3.8	Driver system and push arm connection	10
4	Electrical connection	11-12
5	Parameter adjustment	13-14
6	Quality Assurance Certificate/Qualification Certificate	15

1 Technical parameter

Power supply:200v~240v

Opening time:3~7s/90°

Opening and holding time:1~30s

Temperature:-20℃~+55℃

Protection level:IP12D

Product weight:6.5Kg

Product volume:515x95x90mm

mm= Door width

kg= Door weight

 Optimum scope

 Limit range

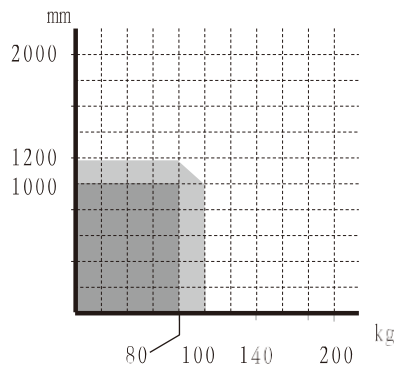

2 Description of accessories

Power cord hole



Floor

Sensor equilibrium hole



Hood

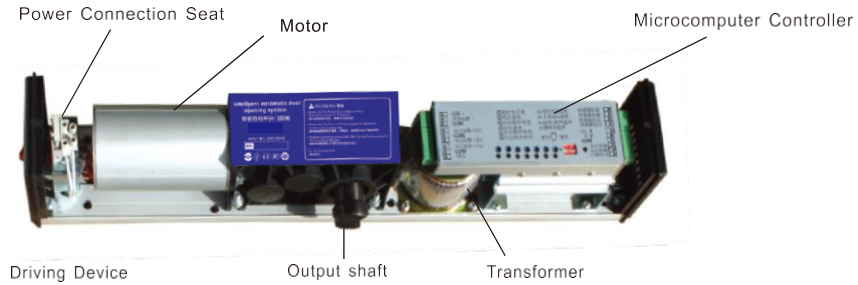

Pull arm (and push arm choose one)



Push arm (choose one from pull arm)

3 Mechanical installation

3.1 Installation example

Pull-arm mounting: Suitable for door wing opening inward (drive system inside)

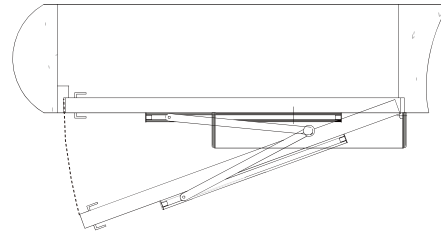
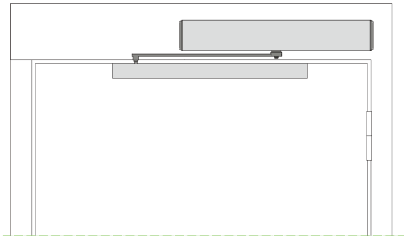

Push Arm Installation: Suitable for door wing opening outward (drive system inside)

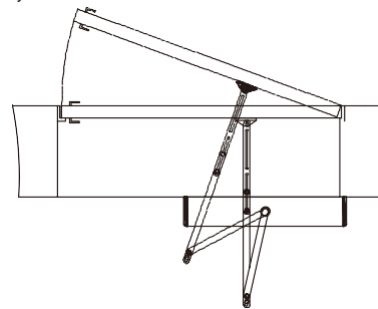
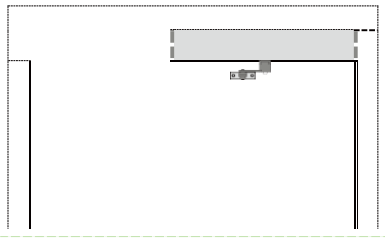

3 Mechanical installation

3.2 Baseboard installation

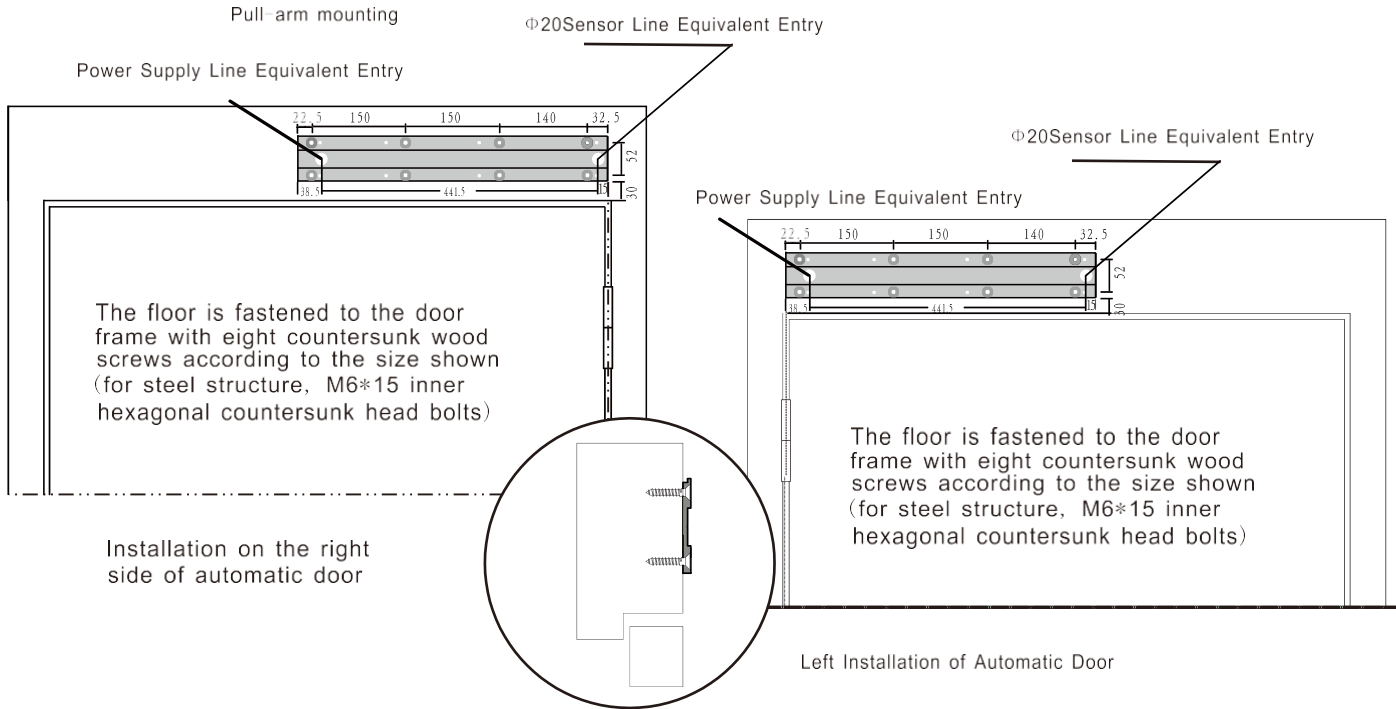

3 Mechanical installation

3.2 Baseboard installation

Push Arm Installation

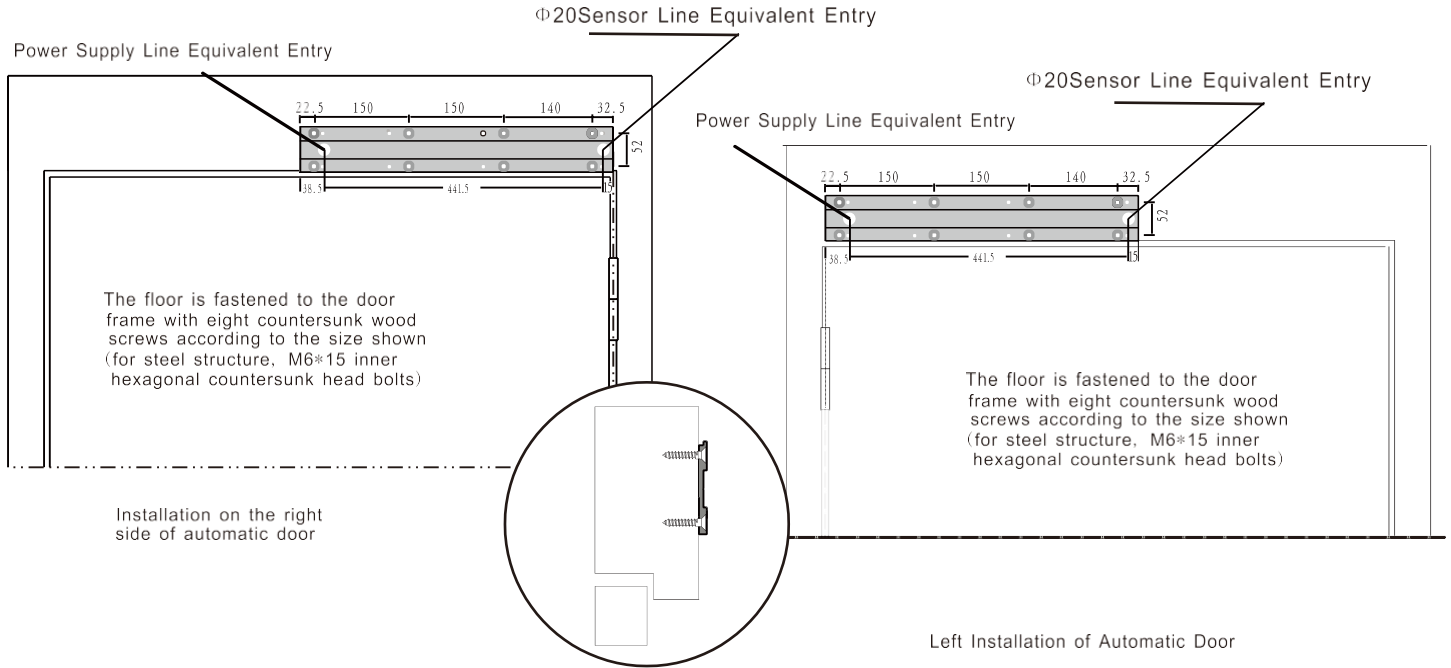

3 Mechanical installation

3.3 Pull-arm mounting

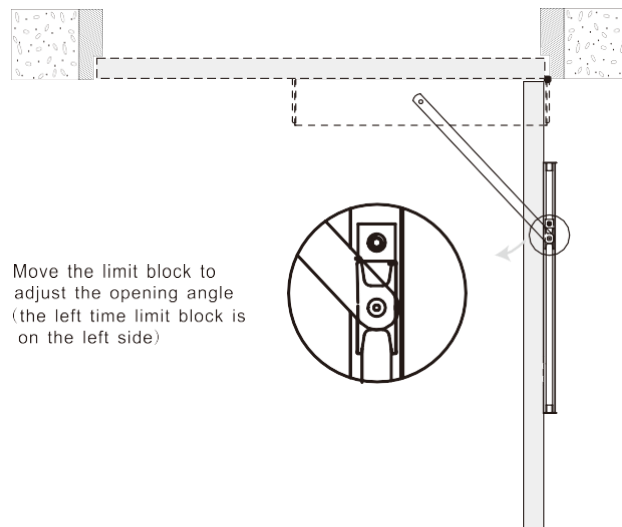
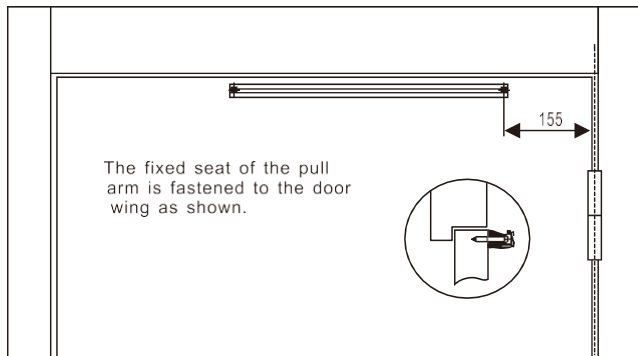

Installation on the right side of automatic door

3 Mechanical installation

3.4 Push Arm Installation

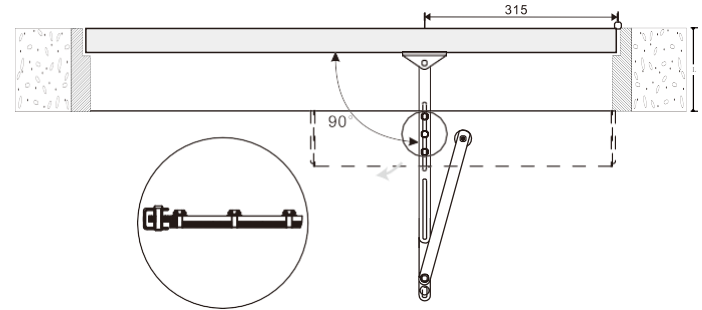
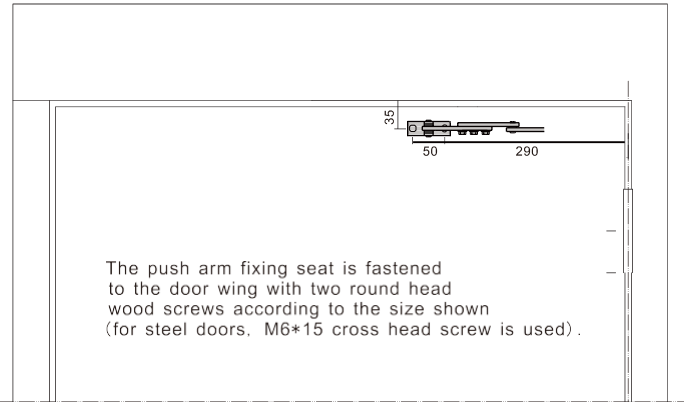

According to the different depth L of the door frame, the length of the push arm can be adjusted by loosening three clamping bolts, so that the angle between the push arm and the door body is 90 degrees as shown in the figure.

Installation on the right side of automatic door

3 Mechanical installation

3.4 Push Arm Installation

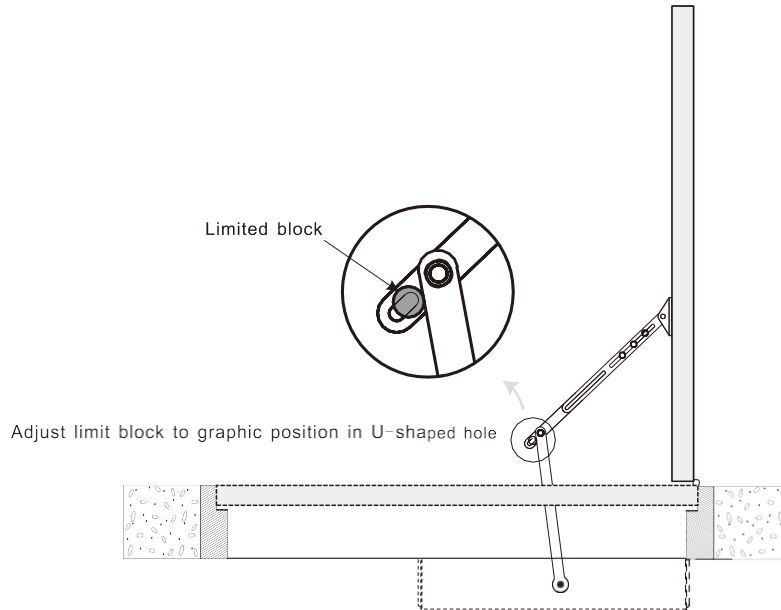

3 Mechanical installation

3.5 Driver system installation

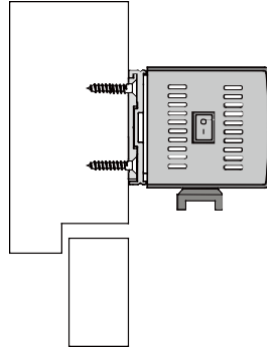
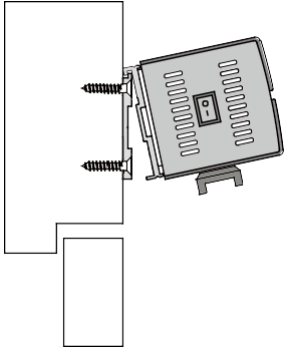

Install the drive system as shown in the illustration on the installed base plate, with eight hexagon socket heads screwed

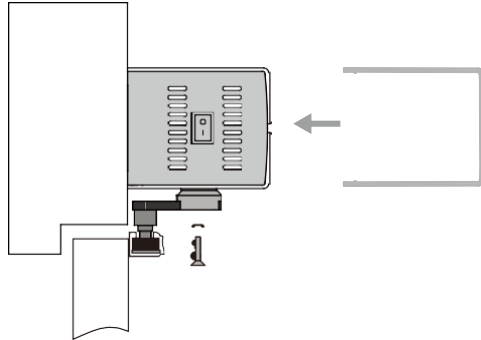

Hood installation

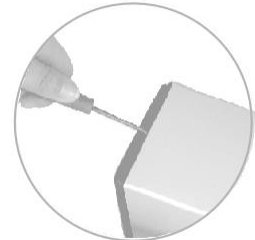

How the hood is opened

3 Mechanical installation

3.7 Drive system and pull arm connection

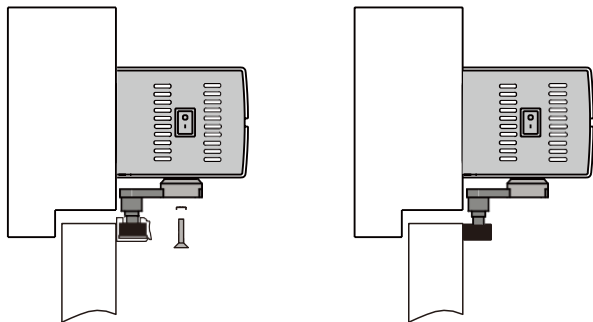

3.8 Drive system and push arm connection

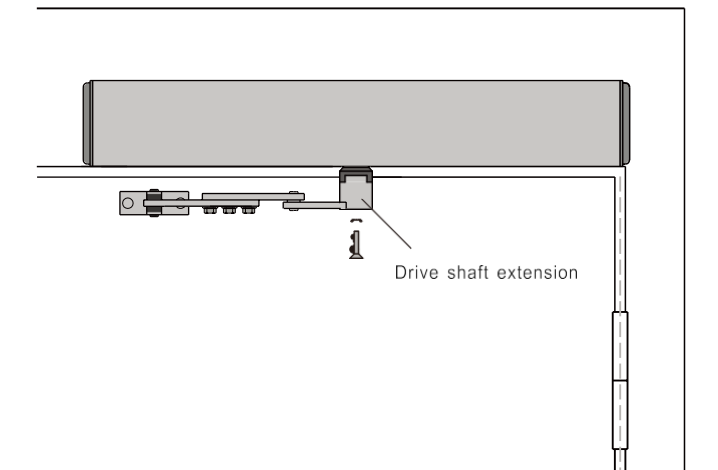

4 Electrical connections

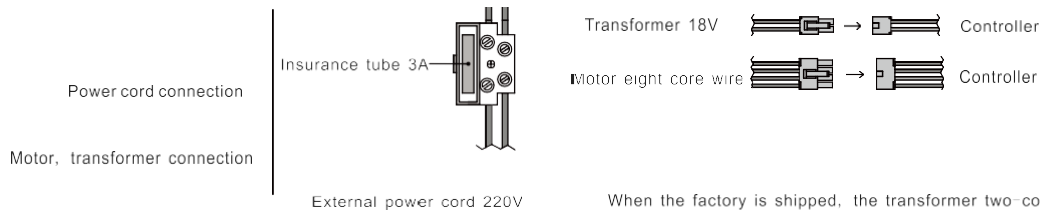

When the factory is shipped, the transformer two-core cable, the motor eight-core cable and the controller are connected.

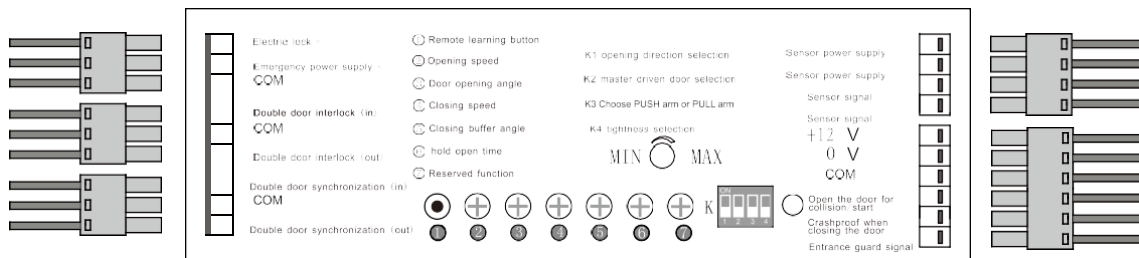

Entrance guard+power supply

Lock the door every time

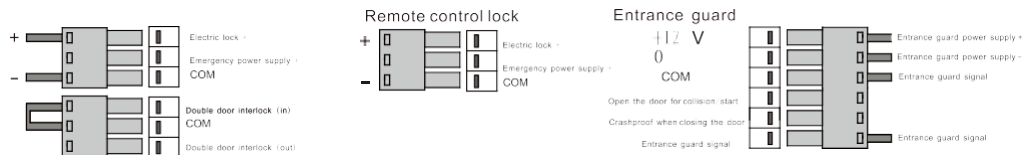

3 Mechanical installation

Double door synchronization



In the double opening door, the first opening and the second closing are set as the active ones, and the rear opening is first set as the driven door, the active door K2 is set, and the driven door K2 is placed.

Sensor, access control and active door controller connection

Double door interlock



Note: When two doors share one sensor or the same source, the double door may open normally. At this point, change the two signal lines of the sensor on one of the controllers to restore normal operation.

5 Parameter adjustment

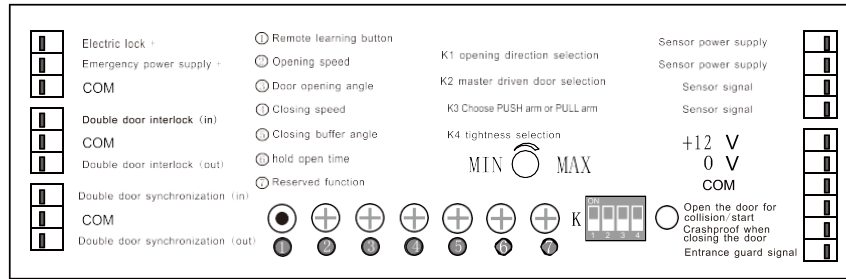

1. Remote learning button
2. Opening speed Clockwise speed is getting faster
3. Buffer angle of opening door Increased clockwise angle
4. Closing speed Clockwise speed is getting faster
5. Buffer angle of closing door Increased clockwise angle
6. hold open time Time is longer in clockwise direction About 7 seconds at 1/4 position About 14 seconds in 1/2 position
7. Reserved function key About 21 seconds in 3/4 position

Switch setting (K): After setting, power off, restart is effective

K1: When the power is turned on, in the initial state, the door moves to the correct position in the direction of closing the door, and if it moves in the direction of opening the door, the switch position is changed.

K2: When the double door is synchronized, the active door is placed and the driven door is placed (on)

K3 Choose PUSH arm or PULL arm

K4: The door is opened and the forbidden force is placed (on)

5 Parameter adjustment

remote control

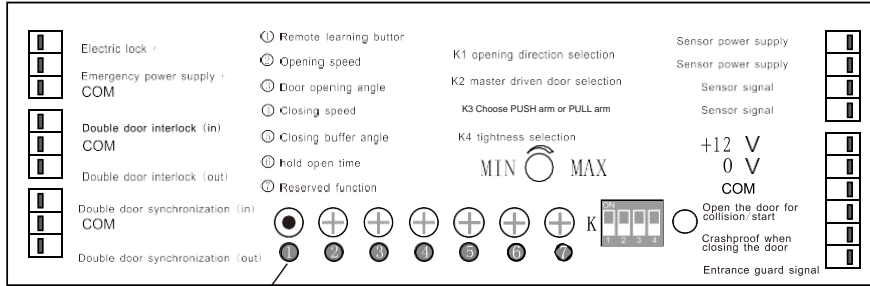

Remote learning button

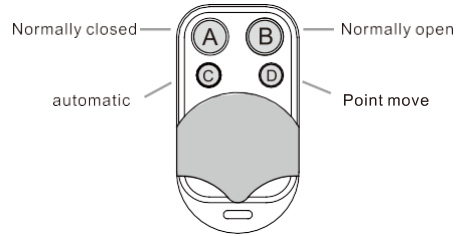

Controller and controller pair code description

1. Empty: Press and hold the "Remote Learning Key" button to know that you can't hear the buzzer sound and release the button.
2. Pair code: Press the "Remote Learning Key" button and the buzzer will sound. At this time, press any button on the remote control, and the buzzer will beep three times, indicating that the code is successful. The buzzer will beep when using the remote control.
3. Note: When using the remote control, the buzzer will beep twice, indicating that the remote control and the controller are not successfully coded. Please repeat item 2.
4. Press the "inching button" button, the door switch once

6 Product Quality Assurance / Certificate

- Under normal conditions of use, due to defects in the manufacture of the product itself, free after-sales service can be obtained during the quality assurance period.
- if there is a problem, please contact our company.
- In the following cases, after-sales service is provided in the form of paid maintenance even if the product is in the quality assurance period.
Malfunctions caused by inadvertent or unsuitable installation, repair, and modification by the user; failures caused by the user not following the items specified in the instruction manual
- Please show the quality guarantee and purchase invoice when maintenance is required.
- Since the company does not reissue the quality guarantee, one machine and one card, please keep it in a safe place.

Certificate	
<u>Product name</u> Intelligent Automatic Door System	
<u>model</u> _____	<div style="border: 1px solid black; width: 100%; height: 100%;"></div>
<u>Manufacturing model</u> _____	
<u>inspector</u> _____	
<u>Manufacturing date</u> _____	

Product name	Intelligent Automatic Door System	Guarantee period	
model			One year
SER.NO			
Purchase date	year month date		
Guarantee period	year month date		to year month
User address			
username			telephone number

- Note: 1. The construction shop should provide customers with one-year warranty and after-sales service, that is, the construction shop should be stamped.
2. The wearing parts are not covered by the warranty

() F: ()

Consumer consultation

China Branch