

With fingerprint

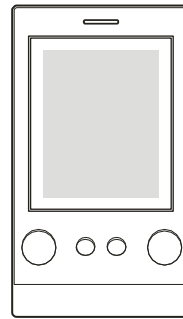

Without fingerprint

1.Introduction

The product is a new generation of multi-function facial recognition Standalone Access Controller and Reader, which utilizes the new powerful, stable and reliable ARM core 32-bit microprocessor design. It can be used as a Weigand reader, or as a Standalone Access Controller/Reader. And is suitable for access control applications in offices, residential communities, villa, banks and prisons.

2.Features

Feature	Specification
Card Type	125KHz EM card(Optional)
	13.56MHz Mifare card (Optional)
Keypad Characteristic	Infrared remote controller operation.
Output Protocol	Can operate as a reader. The transmission format could be adjusted by users.
Access Mode	card, facial recognition , fingerprint, card + fingerprint, card + facial recognition
Admin Card	admin card, admin fingerprint (add/delete)
User Capacity	10,000 card users,1000 facial users and 600 fingerprint users
Facial Recognition Distance	50cm-1m

3.Technical Specifications

Operating Voltage: DC12V	Standby Current: ≤180mA
Operating Current: ≤300mA	Operating Temperature: -40~60°C
Operating Humidity: 0 ~ 95%	Access mode: Fingerprint, card, facial recognition or multiple combination

4.Installation

- Remove the back cover from the keypad using the supplied special screw driver
- Drill 2 holes on the wall for the self-tapping screws and dig a hole for the cable
- Put the supplied rubber bungs into the two holes
- Fix the back cover firmly on the wall with 2 self tapping screws
- Thread the cable through the cable hole
- Attach the keypad to the back cover. (See the figure below)

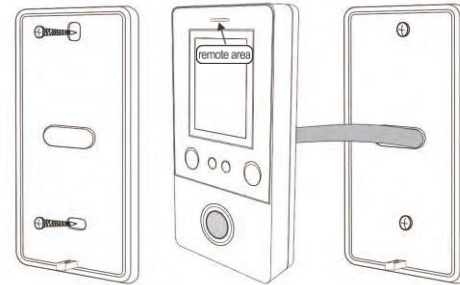

5.Wiring

No.	Color	Marks	Description
1	Orange	NC	Relay NC
2	Purple	COM	Relay COM
4	Blue	NO	Relay NO
6	Black	GND	Negative power supply end
7	Red	+12V	Positive power supply or AC power supply end
8	Yellow	OPEN	Exit button input end
9	White	D1	Wiegand input (only when used as a reader)
10	Green	D0	Wiegand input (only when used as a reader)

6. Diagram

6.1 Common Power Supply

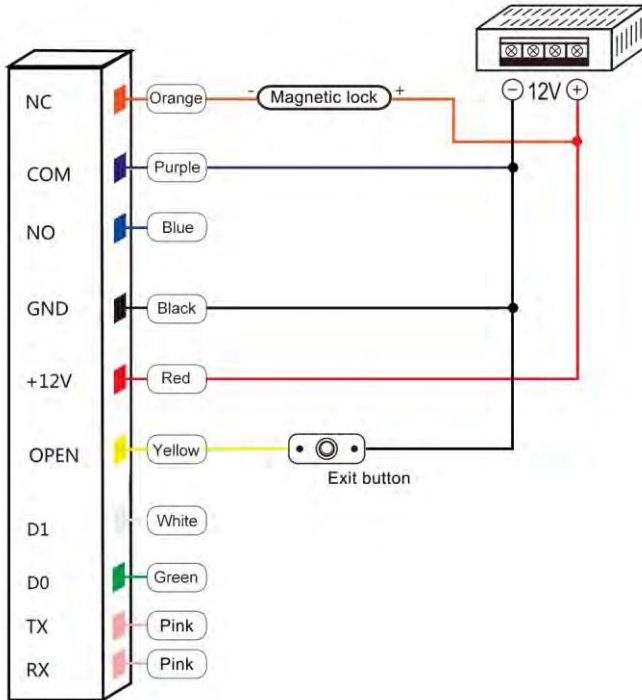

6.2 Special Power Supply

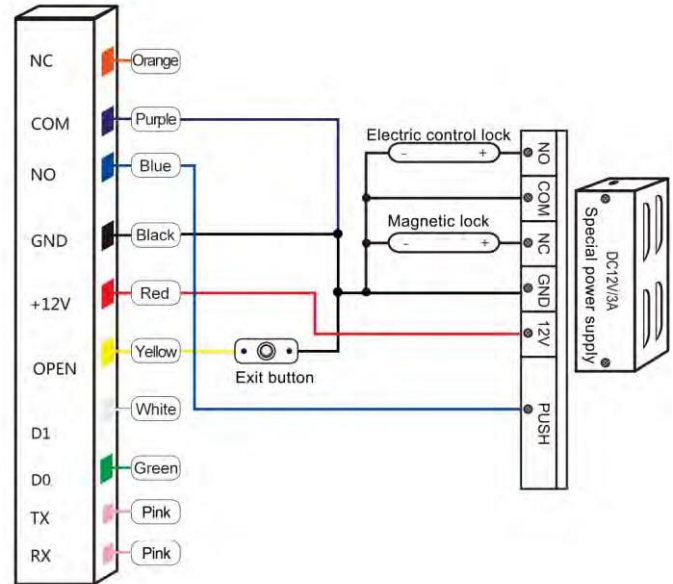

6.3 Reader Mode

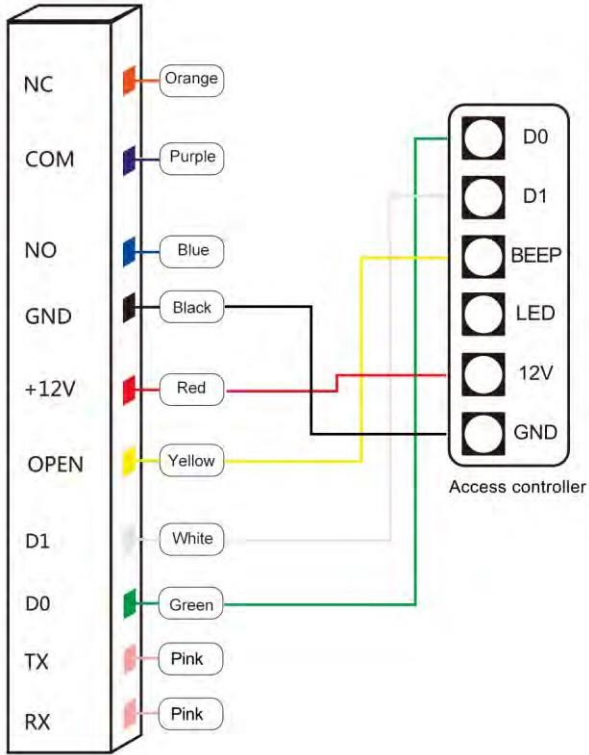

7.Sound and Light Indication

Operation Status	Light indicator	Buzzer
Stand by	Red	
Operation successful	Green	Beep—
Operation failed		Beep-Beep-Beep
Admin card enter programming		Beep—
Admin card exit programming		Beep—
Press digital key		Beep
Press * key		Beep—
Read card under card+fingerprint mode	Red indicator flash slowly	Beep—
Read card under card+facial mode	Red indicator flash slowly	Beep—
Read multi user cards	Red indicator flash slowly	Beep—
Enter programming mode	Red indicator flash slowly	
Enter setting status	Orange	
Unlocking	Green	
Buzzer alarm	Red indicator flash quickly	Alarm

8.Admin Menu

8.1 Standalone Mode Settings

Device Management

Function	Operation steps	Notes
Change Admin Code	* Admin code # 00 New code # Repeat New code #	Factory Default Admin code is 999999. This is the code when you reset the device to factory default
Set Admin Add card or fingerprint	* Admin code # 01 Read card or Fingerprint 3 times *	To set Admin Add card or fingerprint
Set Admin delete card or fingerprint	* Admin code # 02 Read card or Fingerprint 3 times *	To set Admin Delete card or fingerprint
Delete Admin Add card or fingerprint	* Admin code # 01 #	Delete Admin Add card or fingerprint
Delete Admin Delete card or fingerprint	* Admin code # 02 #	Delete Admin Delete card or fingerprint
Exit Programming	*	Press * to exit programming

Common Operation

Function	Operation steps	Notes
Change Admin code	[*] [Admin code] [#] [00] [New code] [#] Repeat New code [#]	Default Admin code is 999999.
Add card user	[*] [Admin code] [#] [11] [Read card] ... [#]	Add multiple card users
Add face user	[*] [Admin code] [#] [12] [Facial recognition 8 times] ... [#]	8 faces per user
Add fingerprint user	[*] [Admin code] [#] [13] [Fingerprint 3times] ... [#]	Each user should present the same fingerprint 3 times. Add multiple fingerprint user.
Delete card user	[*] [Admin code] [#] [21] [Read card] [#]	Delete card user
Delete face user	[*] [Admin code] [#] [22] [Face once] ... [#]	Delete multiple face users
Delete fingerprint user	[*] [Admin code] [#] [23] [Fingerprint once] ... [#]	Delete multiple fingerprint users
Delete all users	[*] [Admin code] [#] [20] [0000] [#]	Delete all card users, faces and fingerprints

Add Users

Function	Operation steps	Notes
Add card user	[*] [Admin code] [#] [11] [Read card] ... [#]	Add multiple card users
Add card number	[*] [Admin code] [#] [11] [8 digits or 10 digits card number] ... [#]	Add card user by inputting card number. User ID number will be generated automatically(1~9999)
Add user ID number + card	[*] [Admin code] [#] [11] [ID number] [#] [Read card] [#]	Add card user by inputting ID number and reading card
Add user ID number + card number	[*] [Admin code] [#] [11] [ID number] [#] [8 digits or 10 digits card number] [#]	Add card user by specifying User ID number and input card number
Add face user	[*] [Admin code] [#] [12] [Facial recognition 8 times] ... [#]	Add multiple face user. Device will take 8 pictures per user
Add face user by specify ID number	[*] [Admin code] [#] [12] [ID number] [#] [Facial recognition 8 times] [#]	Add multiple face user by specifying User ID number
Add fingerprint user	[*] [Admin code] [#] [13] [Fingerprint 3 times] ... [#]	Add multiple fingerprint user

Add fingerprint user by specify ID number	[*] [Admin code] [#] [13] [ID number] [#] [Fingerprint 3 times] [#]	Add multiple fingerprint user by specifying ID number
Add user with combined access mode	[*] [Admin code] [#] [14] [Card+ Facial recognition 8 times] [#]	Entry by Card + Facial recognition
	[*] [Admin code] [#] [14] [ID number] [#] [Card+ Facial recognition 8 times] [#]	Entry by specify user ID number, then reading card and scanning face
	[*] [Admin code] [#] [15] [Card +Fingerprint 3 times] [#]	Entry by card + fingerprint
	[*] [Admin code] [#] [15] [ID number] [#] [Card +Fingerprint 3 times] [#]	Entry by specify user ID number, then reading card and inputting fingerprint
Add user with multiple combined access mode	[*] [Admin code] [#] [16] [ID number] [#] [Consecutive card, Fingerprint, Face] [#]	User ID: 1-50, 2-10 users

Delete Users

Function	Operation steps	Notes
Delete card user	[*] [Admin code] [#] [21] [Read card] ... [#]	Delete card user
Delete card number	[*] [Admin code] [#] [21] [8 digits or 10 digits card number] ... [#]	Delete card user by card number
Delete ID number	[*] [Admin code] [#] [21] [ID number] [#]	Delete card/fingerprint/face user by specify ID number
Delete face	[*] [Admin code] [#] [22] [Facial recognition once] [#]	Delete face user
Delete fingerprint	[*] [Admin code] [#] [23] [Fingerprint once] [#]	Delete fingerprint user
Delete multiple users	[*] [Admin code] [#] [24] [ID number] [#]	Delete multiple users by ID number
Delete all users	[*] [Admin code] [#] [20] [0000] [#]	Delete all user cards, faces and fingerprints

Access ways

Function	Operation steps	Notes
Card or facial recognition or fingerprint	* Admin code # 3 0 #	Entry by card, fingerprint or facial recognition(default value)
Card	* Admin code # 3 1 #	Entry by card only
Facial recognition	* Admin code # 3 2 #	Entry by facial recognition only
Fingerprint	* Admin code # 3 3 #	Entry by fingerprint only
Card + Facial recognition	* Admin code # 3 4 #	Entry by Card + Facial recognition
Card + Fingerprint	* Admin code # 3 5 #	Entry by card + fingerprint
Multiple users	* Admin code # 3 6 #	Entry by multiple cards/multiple faces/multiple fingerprints

Advanced Settings

Function	Operation steps	Notes
Door unlock time	* Admin code # 4 0-300 #	Door opening time range: 0-300S 0 equals to 50mS, factory default value is 5S
Alarm time	* Admin code # 5 0-99 #	Alarm time range: 0-99 min. Alarm time set at 0 means no alarm. Factory default value is 0
Standalone access control mode	* Admin code # 6 0 #	To put the device back to its default factory operation mode
Relay toggle mode	* Admin code # 6 1 #	If enabled, the door will be kept open until the exit button is pressed. To disable, return the device back to standalone access mode as above.
Reader mode	* Admin code # 6 2 #	WG26 Output
Data backup output	* Admin code # 6 7 #	Send the data to external device
Date backup Input	* Admin code # 6 8 #	The device will receive the data
Normal mode	* Admin code # 7 0 #	Without alarm & locked function
Locked mode	* Admin code # 7 1 #	The device will be locked for 10 minutes if invalid cards or codes are presented 10 times continuously
Alarm mode	* Admin code # 7 2 #	The device will alarm if invalid cards or codes were presented 10 times continuously
Enable light indicator	* Admin code # 8 0 #	Indicator light is on under standby
Disable light indicator	* Admin code # 8 1 #	Indicator light is off under standby
Enable buzzer	* Admin code # 8 2 #	Sound activated during the operation
Disable buzzer	* Admin code # 8 3 #	No sound during the operation

9.Admin Card Operation

9.1 Add Card

Read admin add card Read the 1st user card Read the 2nd user card ... Read admin add card

Note: The Admin Add card is used to add card users continuously and quickly. When you present the Admin Add card, you will hear short "BEEP" sounds twice and the indicator light turns orange. You have entered into Add user programming mode. You can present the cards for programming now. After all the cards are added, present the Admin Add card again. You will hear long "BEEP" sound once and the indicator light turns red, indicating that you have exited the Add card user programming mode.

9.2 Delete Card

Read admin delete card Read the 1st user card Read the 2nd user card ... Read admin delete card

Note: The Admin Delete card is used to delete card users continuously and quickly. When you present the Admin Delete card, you will hear short "BEEP" sounds twice and the indicator light turns orange. You have entered into Delete user programming mode. You can now present the cards for deletion. When it is completed, you can present the Admin Delete card and you will hear a long "BEEP" sound once and the indicator light turns red, indicating that you have exited the Delete card user programming mode.

10.User Operation

10.1 Acknowledging the Alarm

Read admin card or Read valid user card or Input valid fingerprint or Press Admin code #

Note: When the alarm is activated, users can acknowledge and stop the alarm by reading valid user or Inputting valid fingerprint or pressing admin code.

10.2 Reset to Factory Default

Users can reset to device to its factory default if the Admin code is forgotten or the user wants to place the device back to factory original settings.

To reset, follow the procedures below:

Power off the device. Hold down the Exit button. Power on. Release the Exit button only when you hear the beep sound twice. The Admin code has been reset to 999999, factory and the device has defaulted to factory setting

Note: Note: Registered user data won't be deleted when reset to factory default.

10.3 Data Backup Operation

Example: Backup the data of machine A to machine B

The pink wire of machine A connects the pink-white wire of machine B, the pink-white wire of machine A connects the pink wire of machine B, set B for receiving mode at first, then set A for sending mode, the indicator light turns green flash during the data backup, data backup is successful when indicator light turns red.